

PetStar 4

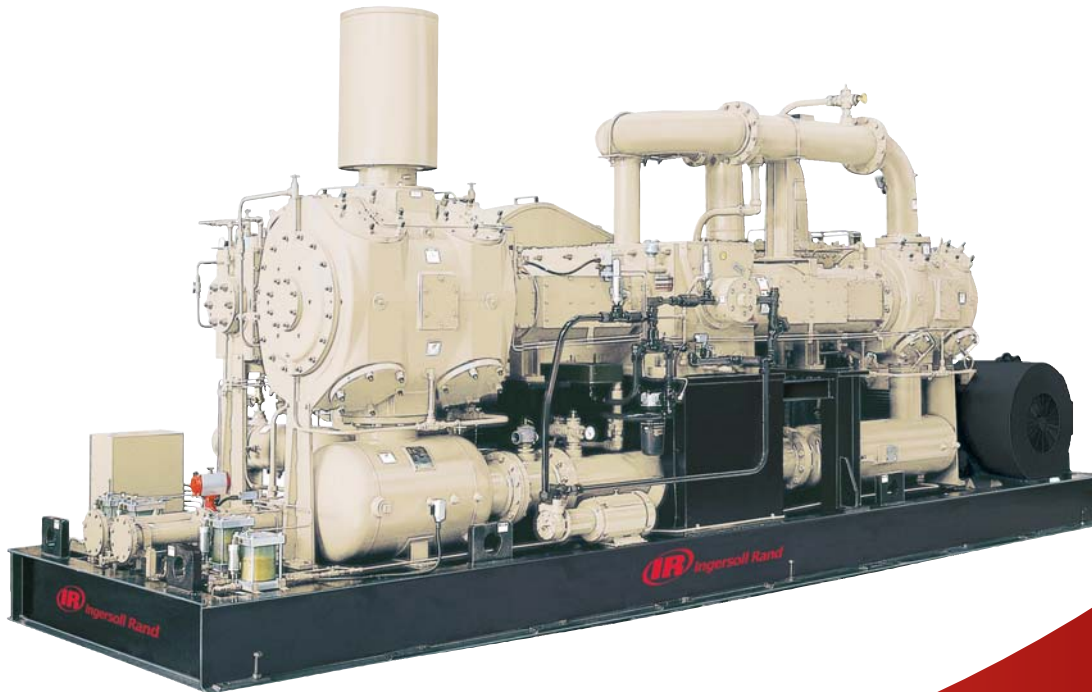

Standard Features:

- ✓ Nonlubricated 100% Oil Free Water-Cooled Design
- ✓ Four-Stage Balanced Opposed Layout Eliminates Unwanted Vibration
- ✓ All Double Acting, Heavy Duty Class 40 Cast Iron Cylinder Construction
- ✓ 16,000 Hour Rated Piston Rings and Packing
- ✓ Worldwide Service and Parts Support
- ✓ Sleeve Type Main and Connecting Rod Bearings
- ✓ Anticorrosion Coating On All System Air Piping
- ✓ Crankshaft-Driven Main Oil Pump
- ✓ Large Cast-In Water Jackets For Dimensional Stability Under Extreme Conditions
- ✓ State-of-the-Art Control System

PetStar 4

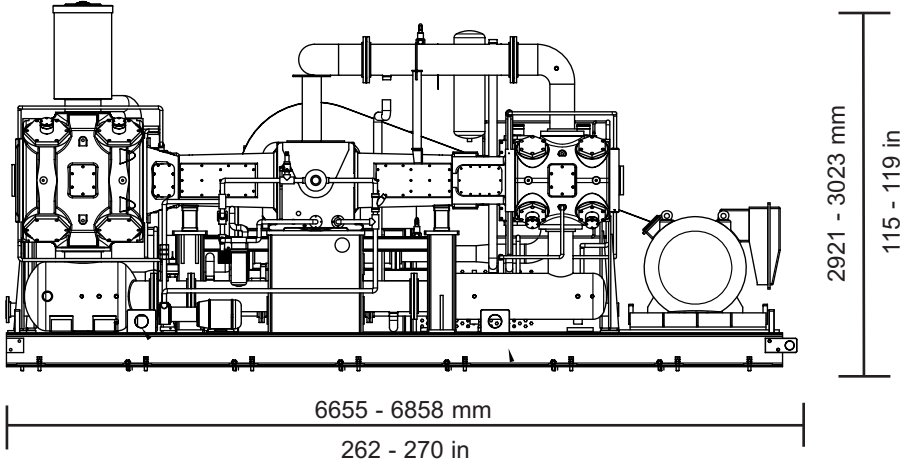

Standard Package Scope of Supply Includes:

- Interstage temperature and pressure sensors to keep close track of system parameters
- Heavy-duty welded steel sub-base
- Crankshaft driven mail oil pump
- Anti-corrosion coating on all system air piping
- Electrical driven pre-lubrication system
- Advanced CMC main compressor controller with 1,000 event logging capability built-in

Optional:

- Available with Enduralife components which include 16,000 hour rated rings and packing, Patented Magnum non-metallic valves, easy to service and equipped with PEEK sealing elements yielding 2-3 times the operational life of comparable plate valves and Rod drop position wear indicators

Model	Nominal Capacity		Pressure Range		Width		Dimensions Height		Length		Weight		Sound Pressure dBA
	cfm	m3/min	bar (a)	psi	in	mm	in	mm	in	mm	lb	kg	
PS-4 1500	918	26	40	580	90	2565	115	2921	262	6655	47700	21500	90
PS-4 1700	1037	29									48000	21800	
PS-4 1900	1156	33									48300	22000	
PS-4 2100	1287	36									48700	22200	
PS-4 2300	1416	40									49600	22650	
PS-4 2500	1534	43					50700	23000					
PS-4 2800	1713	48					51000	23200					
PS-4 3000	1831	52					51300	23300					
PS-4 3300	2023	57					52500	23900					
											119	3023	

* Weights and dimensions may vary according to the options chosen.

** Performance data is basis reference conditions of 1 bar inlet pressure and 20°C inlet temperature. Please contact us for further information.

*** Sound measurement basis free field conditions. Please contact us for further information



Ingersoll Rand Industrial Technologies provides products, services and solutions to enhance the efficiency and productivity of our commercial, industrial and process customers. Our innovative products include air compressors, air systems components, tools, pumps, material and fluid handling systems and microturbines.

Ingersoll Rand Industrial Technologies
Air Solutions
800-B Beaty Street
Davidson, NC 28036
Office 704-655-4000
Fax 704-655-4537
www.air.irco.com